



Fat-Tad Supplemental Owner's Manual



CONGRATULATIONS!

Congratulations and welcome to the Sun Seeker Recumbent family! You have selected one of the most comfortable and advanced recumbents on the market. Please read this manual before riding your Sun Seeker Recumbent. In this manual you will find that we cover the basics for setting up and understanding your new recumbent.

IMPORTANT:

This manual is only a supplement to the main Recumbent Bicycle/Tricycle Owner's Manual. Read it before you take the first ride on your new recumbent bicycle/tricycle, and keep it for reference.

NOTE:

This manual is not intended as a comprehensive use, service, repair or maintenance manual. Please see your dealer for all service, repairs or maintenance. Your dealer may also be able to refer you to classes, clinics or books on bicycle use, service, repair or maintenance.

Fat-Tad Specifications

Model:	Fat-Tad CX
Style:	Tadpole Trike
Frame Material:	Tig Welded Chromoly with Rear Coil Over Suspension
Fork Material:	High Tensile Steel with Integrated Suspension
Handlebar Material:	Chromoly Steel
Steering System:	Direct Linkage
Seat Type:	1-piece - Padded Base w/Alloy Frame & Full Mesh
Wheelbase:	59" (150cm)
Overall Length:	78" - 83-1/2" (198-212cm)
Width:	33-1/4" (92cm)
Bottom Bracket Height:	20"-21-1/2" (51-55cm)
Seat Height:	16-1/2"-17-3/4" (42-45cm)
Weight:	57 lbs.
X-Seam :	37" - 50-1/2" (94-128cm)*
Weight Limit:	300 lbs.
Gear Inch Range:	15 - 88
Headset:	Sealed Mechanism Steel
Drive Type:	Direct 24-speed Derailleur
Pedals Type:	Platform
Crankset:	Triple Alloy 170mm 42/32/22T
Bottom Bracket:	Sealed Cartridge
Chain Type:	KMC Z-71
Front Derailleur:	Sunrace
Rear Derailleur:	SRAM
FW/Cassette Range:	11-34 8 Speed
Shifters Set:	SRAM
Brake Levers:	Promax Locking Linear Pull
Brake Caliper Front/Rear:	Promax Mechanical Disc / nil
Rims / Spokes:	Alloy Fat Single Wall / Stainless Steel
Tires / Size:	Fat Bike Knobby / 20x4.0
Water Bottle Cage Mounts:	2-Handlebar / 2-Seat Back
Note: Specifications subject to change without notice. * Boom modification may be required from 37" - 40"	

Fat-Tad Reference Views

Side View

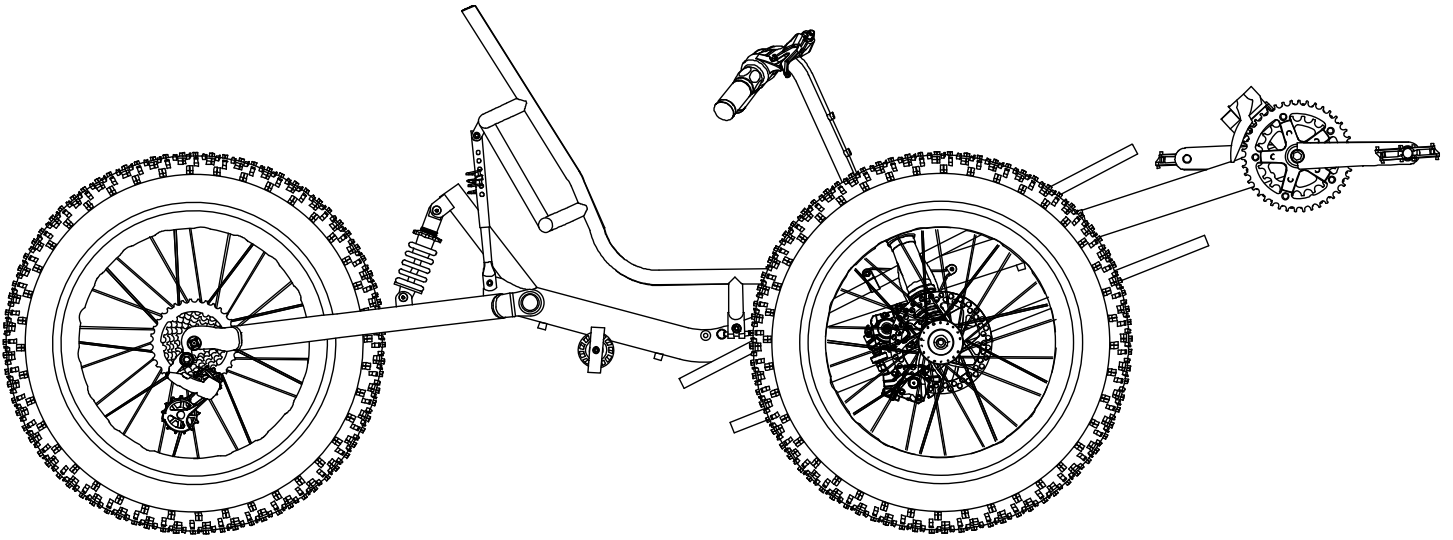

Top View

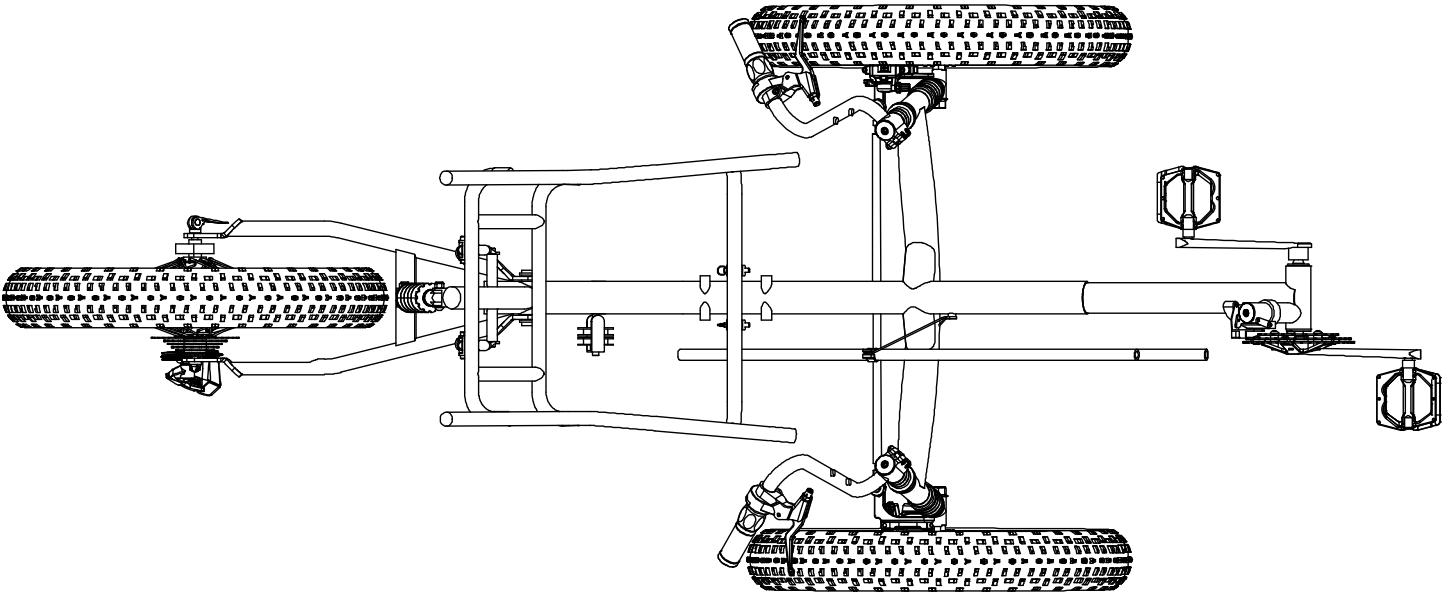

Fat-Tad Assembly Reference

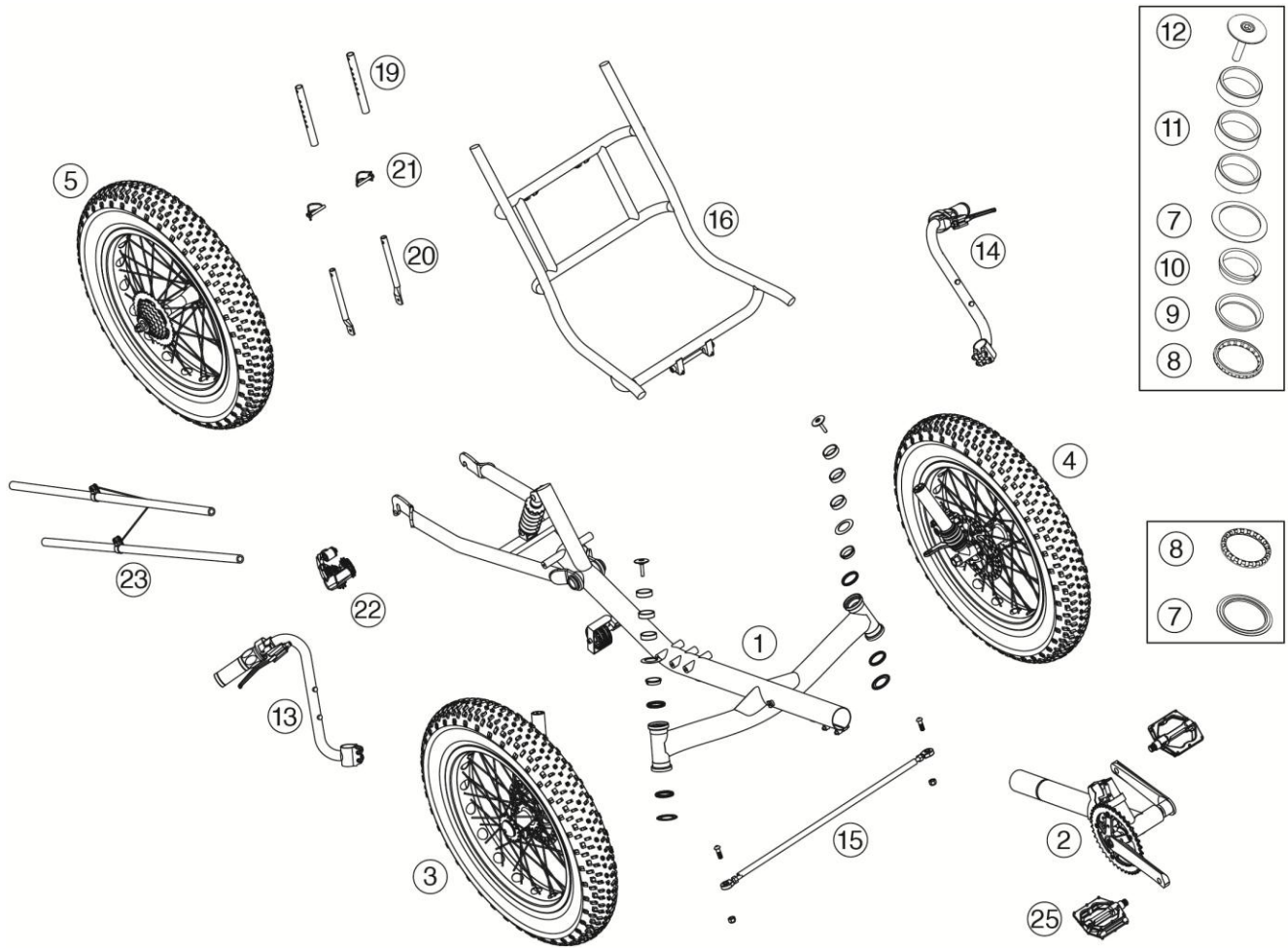

FAT-TAD PARTS LIST		
ITEM	DESCRIPTION	QUANTITY
1	Main Frame	1
2	Crank Boom Assembly	1
3	Right Front Wheel Assembly	1
4	Left Front Wheel Assembly	1
5	Rear Wheel Assembly	1
6	Quick Release for Rear Wheel (Not Pictured Above)	1
7	Headset Seal	4
8	Headset Bearing	4
9	Headset Adjust Cone	2
10	Headset Compression Ring	2
11	Headset Spacer 10mm	6
12	Headset Top Cap & Bolt	2
13	Right Handlebar Assembly	1
14	Left Handlebar Assembly	1
15	Steering Linkage Assembly	1
16	Seat Frame Assembly	1
17	Quick Release Seat Pins (Not Pictured Above)	2
18	Seat Mesh (Not Pictured Above)	1
19	Upper Seat Strut (16.3mm x 150mm)	2
20	Lower Seat Strut (19.1mm x 400mm)	2
21	Seat Strut Pin	2
22	Rear Derailleur	1
23	Chain Tube Assembly	2
24	Chain (Not Pictured Above)	1
25	Pedals (9/16")	1

Assembly Guide

Front Wheel and Handlebar Installation

Install #7 Headset Seal and #8 Headset Bearing (after lubricating bearing with grease) onto steer tube of the #3 Right Front Wheel Assembly. Insert steer tube into right-hand head tube. See Figure A.

Install #8 Bearing (after lubricating bearing with grease,) #7 Headset Seal, #9 Headset Adjust Cone, #10 Headset Compression Ring and two (2) #11 Headset Spacers onto the steer tube. See Figure B.

Install #13 Right Handlebar Assembly and one (1) #11 Headset Spacer onto the remaining top portion of steer tube of #3 Right Front Wheel Assembly. Install #12 Headset Top Cap and Bolt as shown in Figure B. Position bar temporarily, adjust bearings using #12 Headset Top Cap and Bolt and then secure handlebar bolts. See Figure W for final adjustment.

Install #4 Left Front Wheel Assembly

Follow above procedure using the #4 Left Front Wheel Assembly.

Install #14 Left Handlebar Assembly

Follow above procedure using the #14 Left Handlebar Assembly.

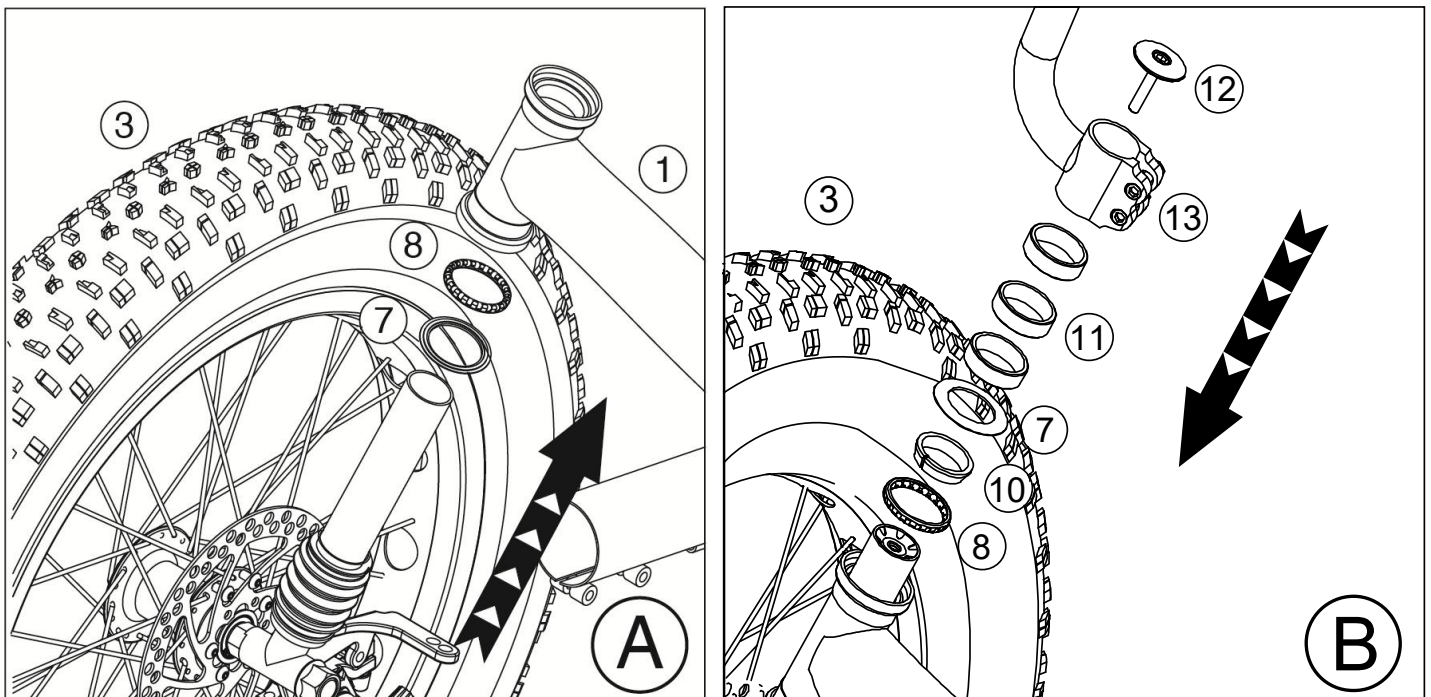

Steering Linkage Installation

Install #15 Steering Linkage Assembly, using supplied hardware, into the inboard Steering Arm Tab holes (closest to rider.) See Figures C, D, E.

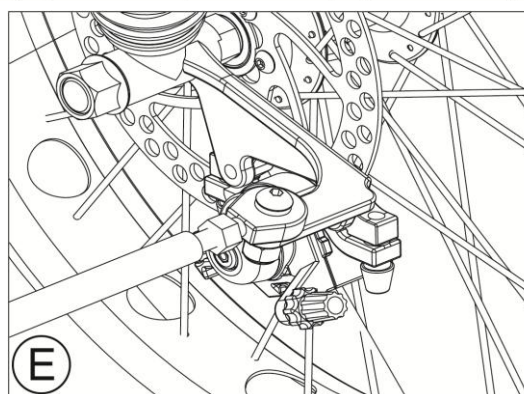
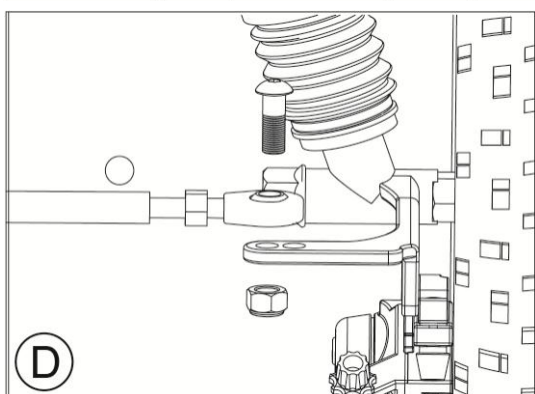
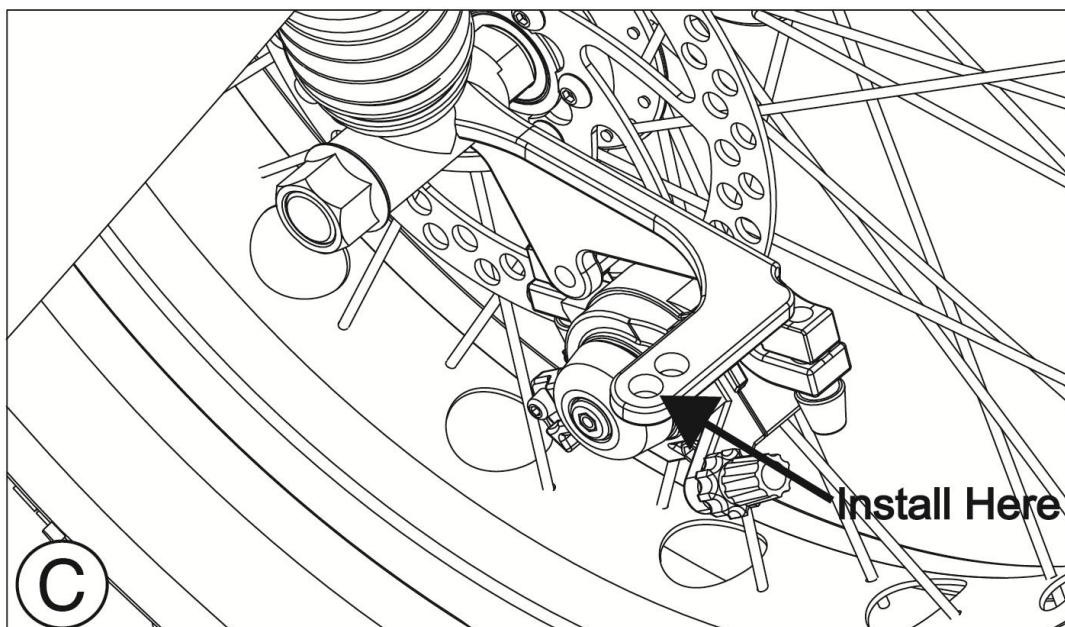

Rear Wheel and Derailleur Installation

Install #5 Rear Wheel Assembly into the rear frame drop outs. Tighten quick-release properly. See Figure F.

Install #22 Rear Derailleur onto the rear frame derailleur tab. See Figure G

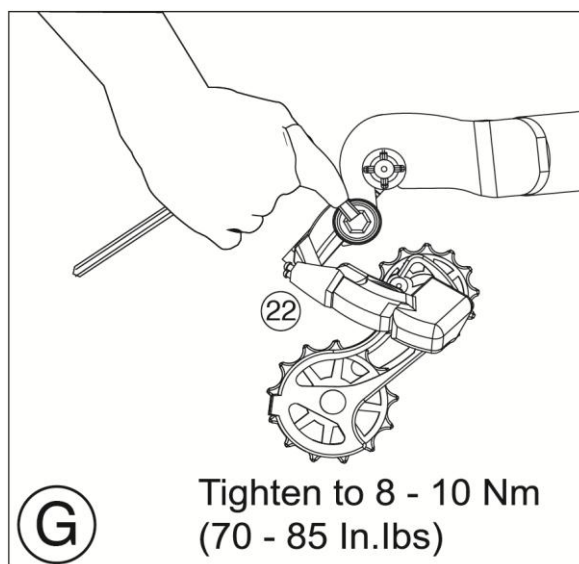
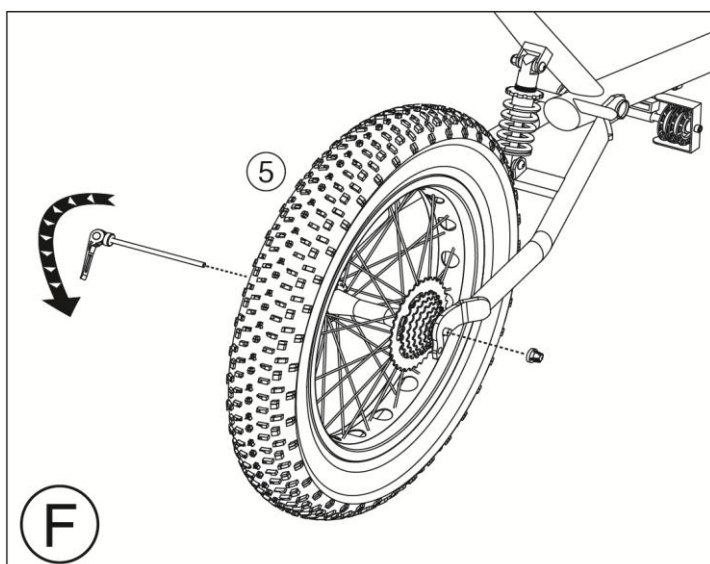

Setting Front Wheel Toe-In Angle

With the trike on the ground and wheels fixed in the straight ahead position, measure from the front of the left wheel centerline across to the front of the right wheel centerline. Record that measurement. See Figure H.

Repeat the above for the rear left wheel centerline across to the rear right wheel centerline. Record that measurement. The measurement should be the same or up to 3mm greater than the front centerline. (0mm to 3mm recommended) See Figure I.

Hint for a simple measuring technique: Use a tape measure and hook one end on an inside spoke at the centerline of the left front wheel and measure to the opposing inside spoke on the front of the right hand wheel. Use the same technique at the rear.

To adjust the toe in, loosen the Rod End Jam Nuts on the #15 Steering Linkage Assembly. Turn the #15 Steering Linkage Assembly clockwise or counter clockwise. This will lengthen or shorten the rod since the rod ends are right hand threaded on one side and left hand threaded on the other. See Figure J.

Tighten the Rod End Jam Nuts and recheck the wheel toe-in. Readjust if necessary.

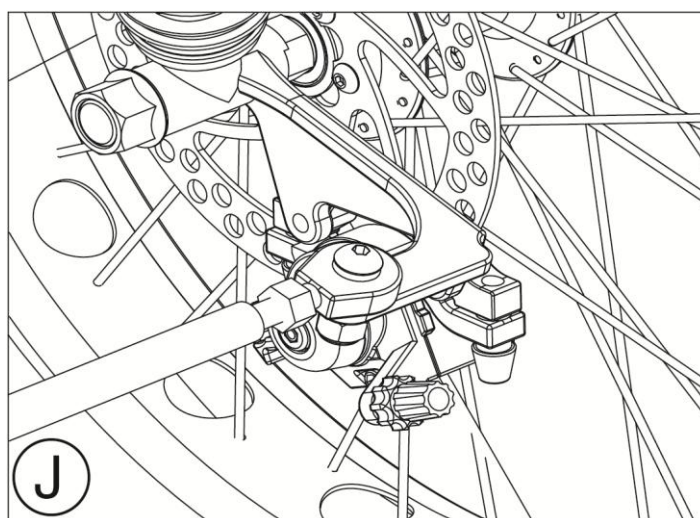
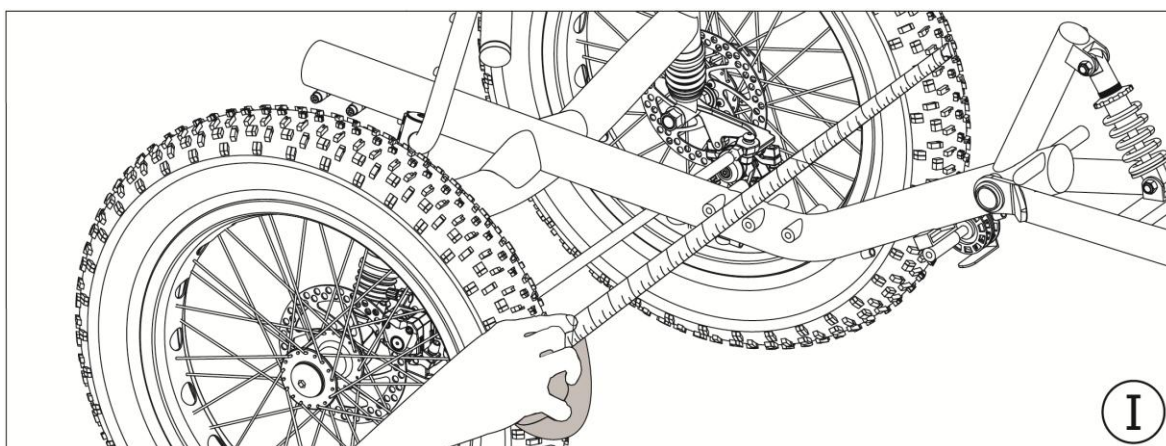
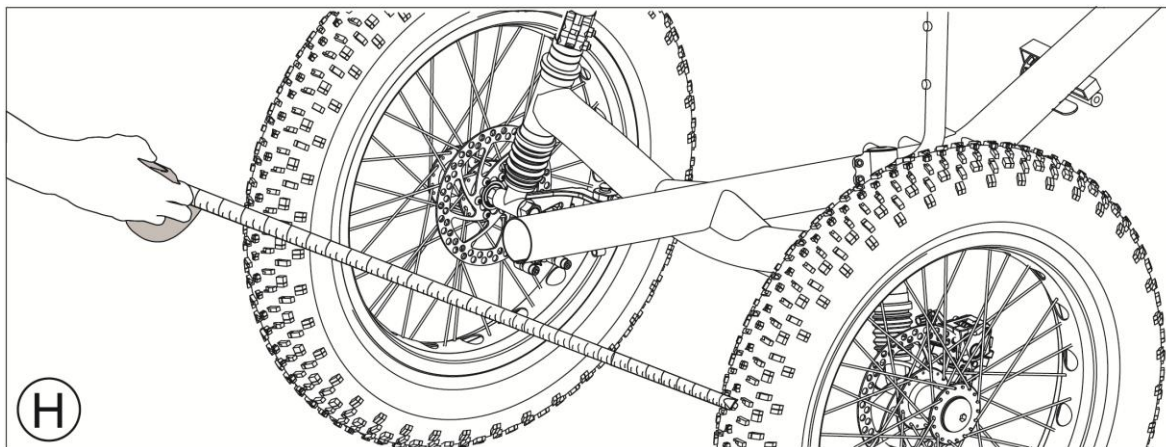

Crank Boom Installation

Install #2 Crank Boom Assembly into the front on the frame. For now, insert midway and secure crank boom bolts. See Figure K.

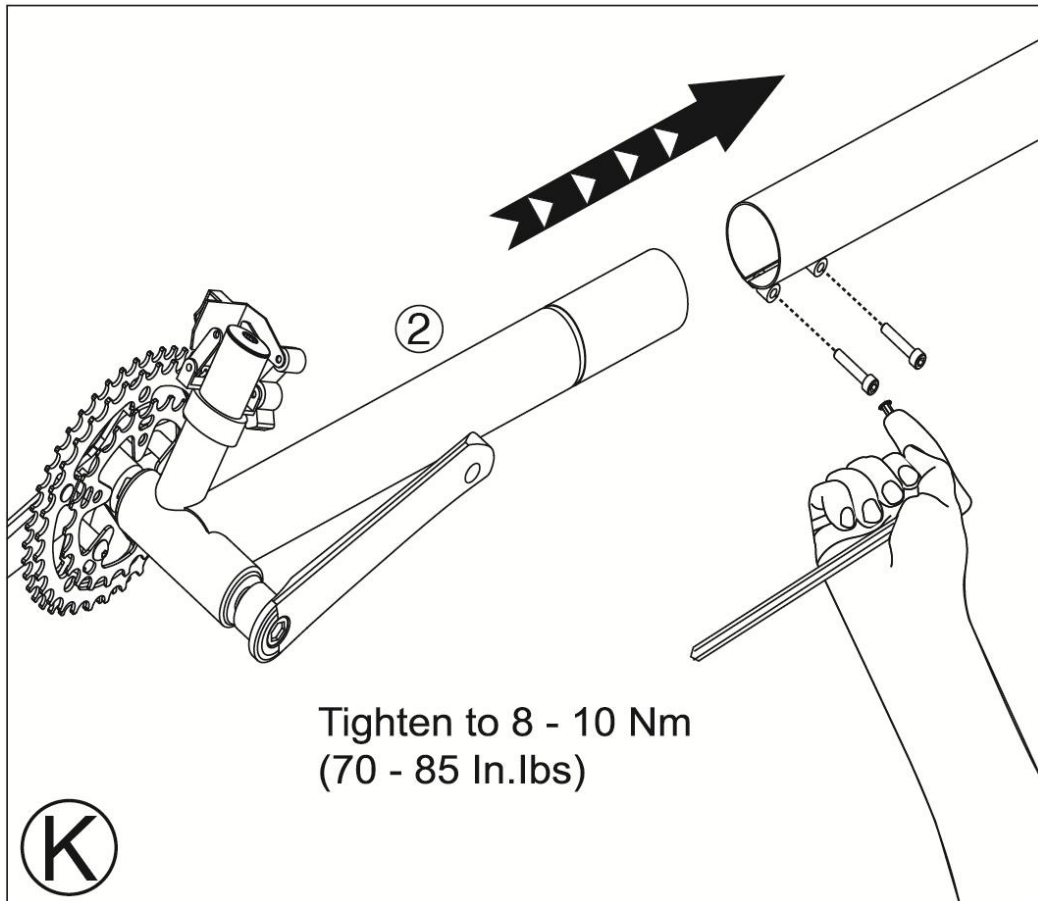

NOTE: DO NOT extend #2 Crank Boom Assembly past the safety line marked clearly on the boom. See Figure L.

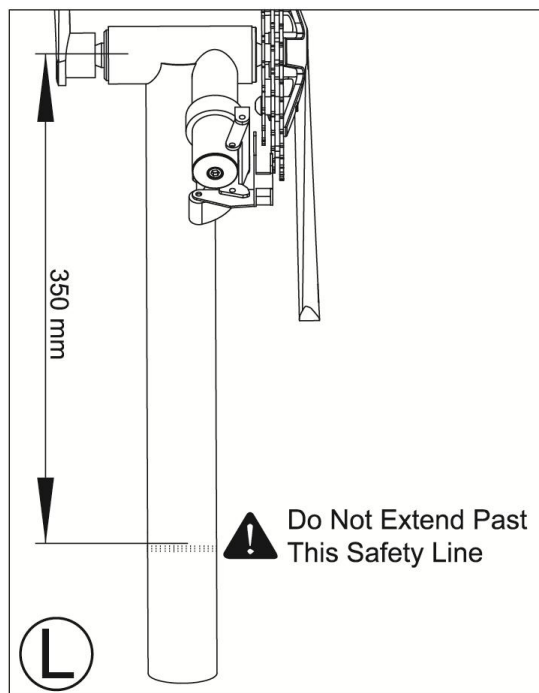

Chain and Chain Tube Installation

Route chain through front derailleur and then into the #23 Chain Tube Assembly. Position the longer chain tubes above the front axle and the shorter one below with the ends of the chain to the rear of the trike. Also make sure the “Y” spring brackets are pointed toward the rear of the trike.

To install chain onto crank, pull just enough chain out of #23 Chain Tube Assembly to go around chainring. See Figure M.

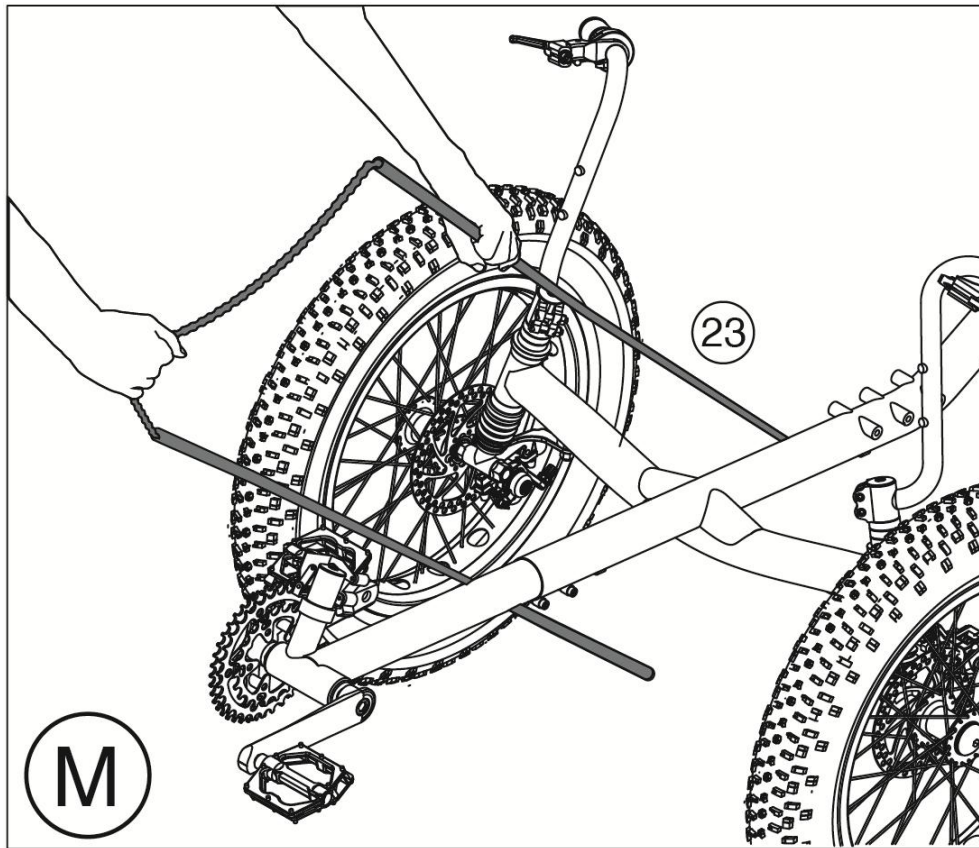

Route the chain over and under the Idler pulleys, around the freewheel and through the rear derailleur. See Figure N.

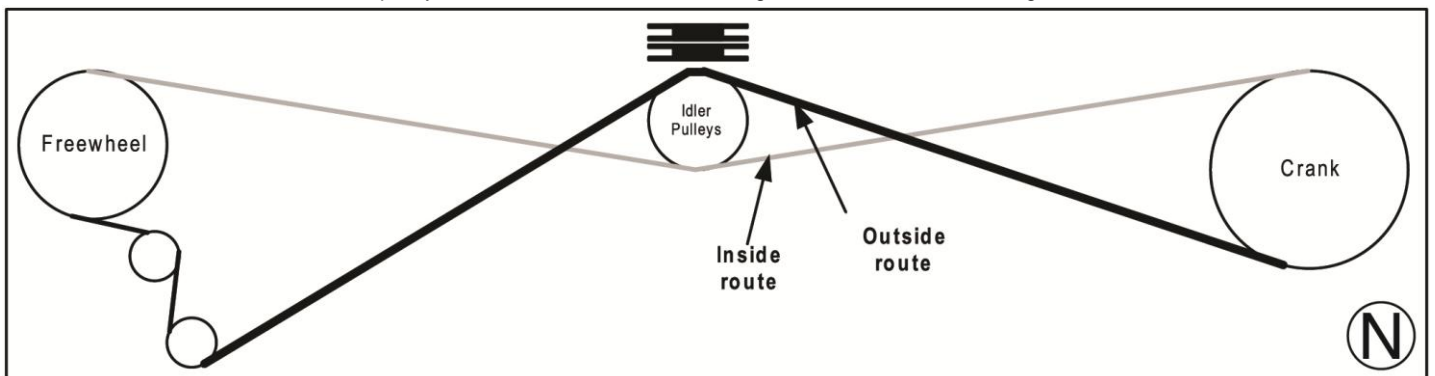

Route the open end of the chain through the rear derailleur, then close the chain.

Install chain tube brackets and springs, secure the chain tube springs to the frame.

NOTE: Chain length is set for crank boom at its fully extended position. Chain and chain tubes may have to be shortened as necessary. Do not shorten until the rider has been fitted properly.

NOTE: Adjust the chain tubes to be far enough from the crank to not affect shifting.

Seat Assembly and Installation

Install M10x110 Bolt through set of holes toward the back of #1 Main Frame and secure with nut provided. See Figure P.

Install #16 Seat Frame Assembly onto M10x110 Bolt and secure with #17 Quick Release Seat Pins. See Figure O & Q.

Install two (2) #19 Upper Seat Struts and four (4) 1/2 moon washers to the seat frame using the provided hardware.

Install two (2) #20 Lower Seat Struts to the rear mounting posts using the provided hardware.

Insert the lower struts into the upper struts and use two (2) #21 Seat Strut Pins to secure the struts. See Figure R.

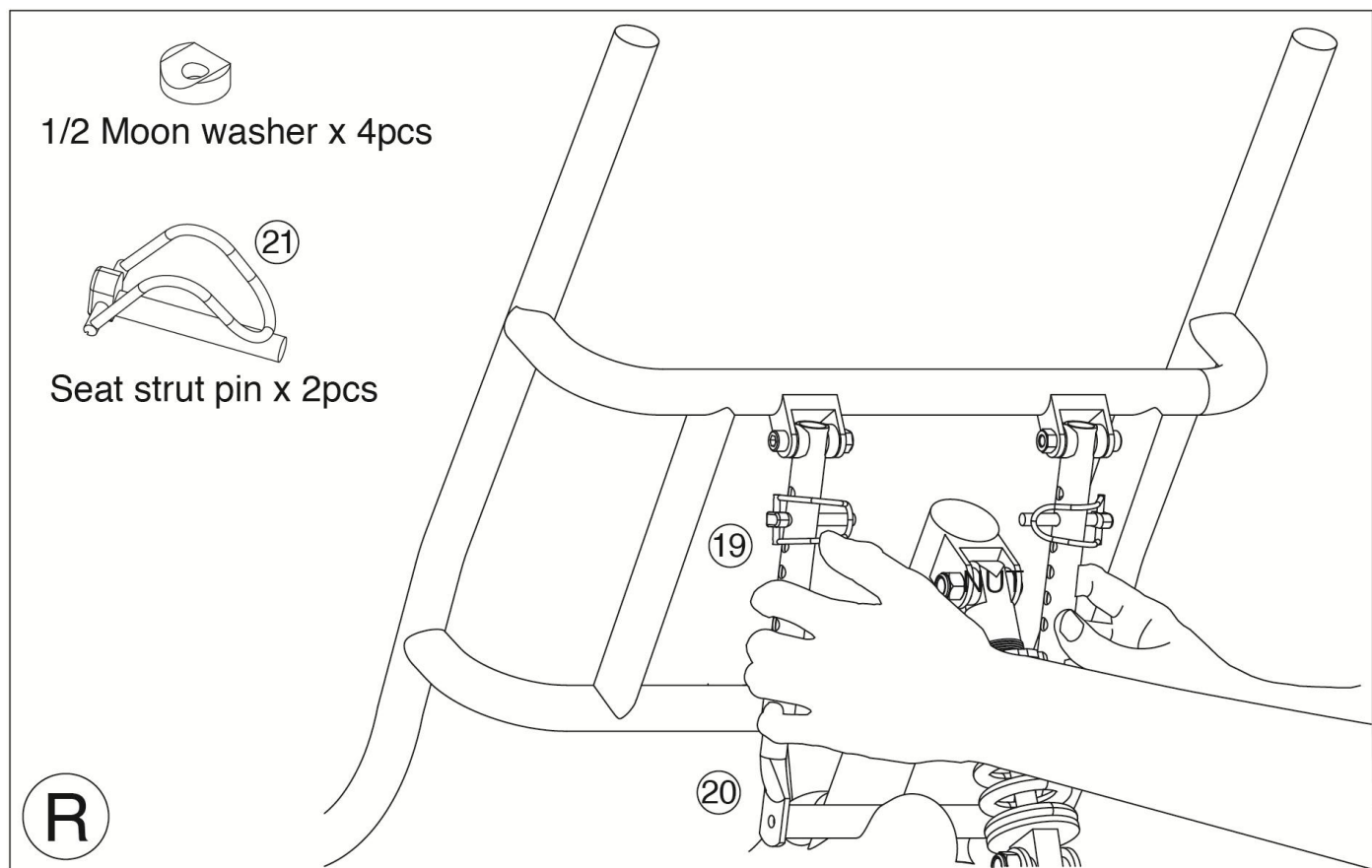
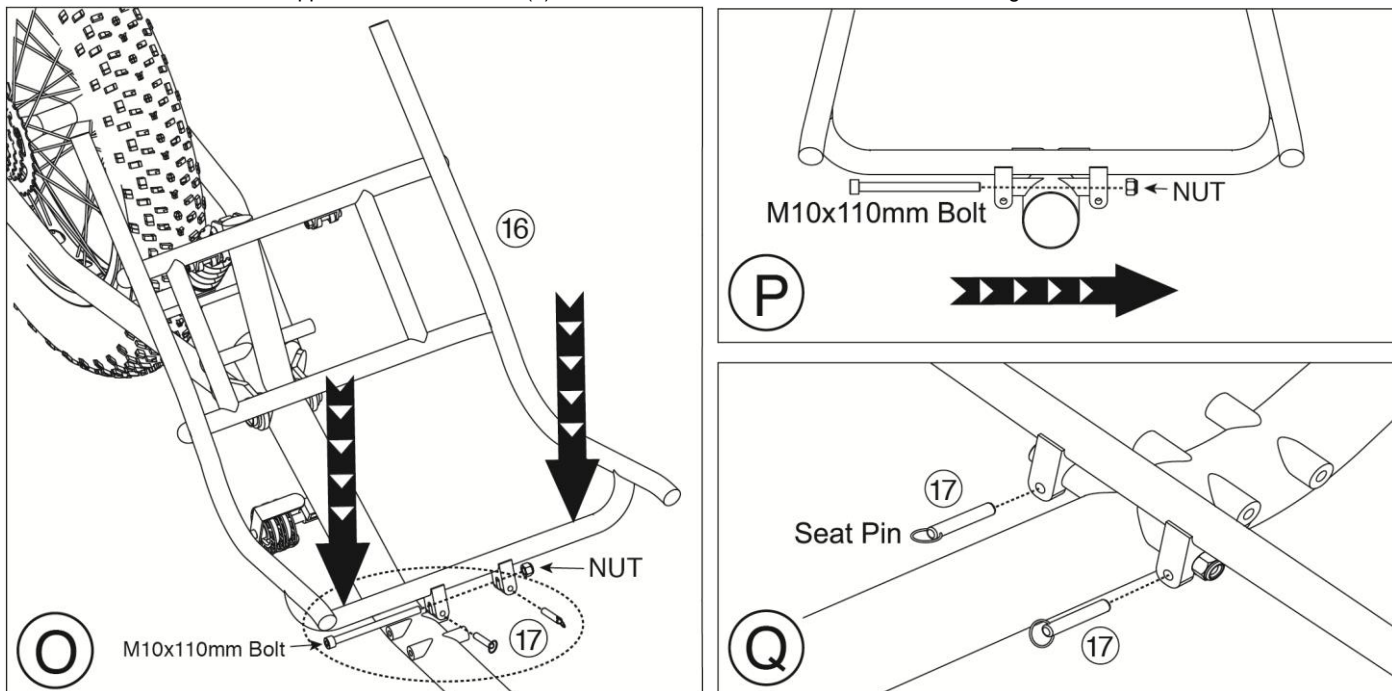

Pedal Installation

Apply grease to the threads of the #25 Pedals. This will protect both the threads of the pedal and the crank arm over time. Use pedal washers where required.

Using your hands, thread the #25 Pedals (marked for L or R) into the respective left or right crank arms by turning them toward the front of the bike.

Once the threads catch, use your pedal wrench to finish tightening down the pedals. See Figure S.

Tighten the pedals to a minimum of 300 in-lbs. of torque.

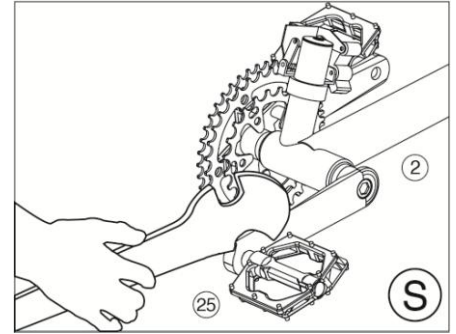

Adjusting Seat and Boom

The goal is for your seat (and therefore your weight) to be as far back as possible when your setup is complete.

Adjust the seat angle by removing the #21 Seat Strut Pins and sliding the seat struts into a new position if necessary. Reinstall #21 Seat Strut Pins after adjustment. See Figure T.

Loosen the #2 Crank Boom Assembly (Figure K) clamp bolts and position the boom so that when seated, your knee is slightly bent when the forward foot is in the farthest pedaling position. See Figure U.

Re-tighten the #2 Crank Boom Assembly (Figure K) clamp bolts to the specified torque setting.

If you cannot extend your leg forward enough in the closest crank boom position to pedal comfortably, you may move the seat forward on the #1 Main Frame by reinstalling the M10x110mm bolt into a closer set of holes toward the front to get the proper fit.

Note: Your chain may need to be lengthened or shortened depending on your final seat and crank boom position. Seat struts can be trimmed and re-drilled as necessary to provide a perfect fit.

 **CAUTION:** Never lubricate or wax the part of the boom that goes into the frame. See Figure V.

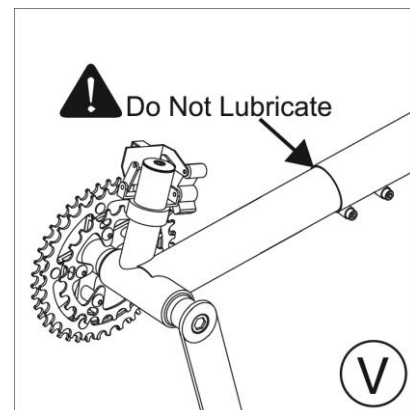
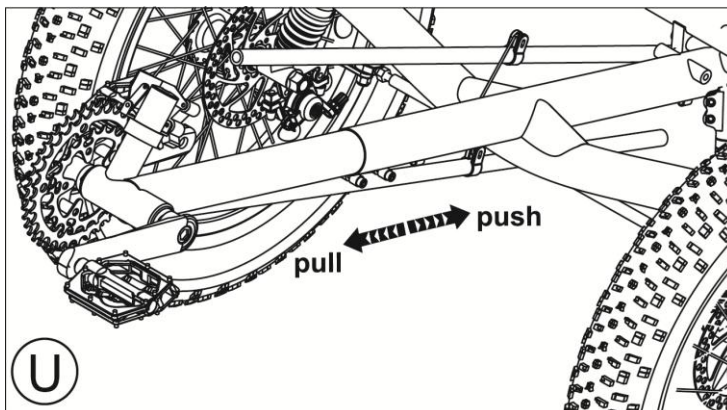
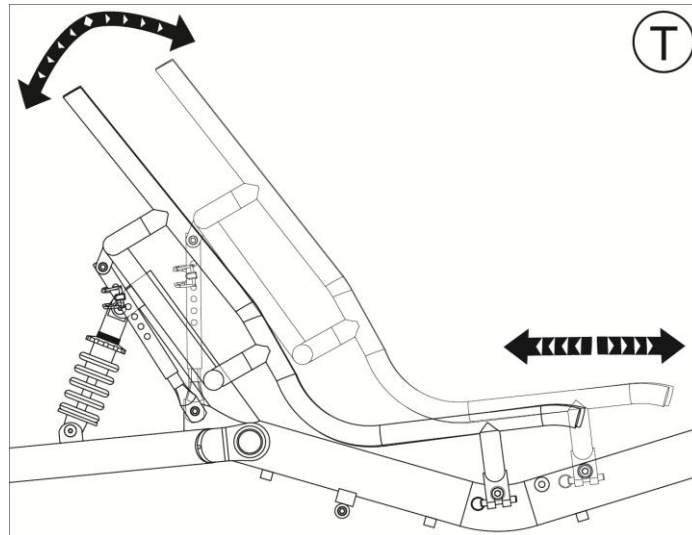

Adjusting Handlebars and Headsets

Loosen the clamp bolts that secure your #13 Right Handlebar Assembly to the steer tube then carefully loosen the #12 Headset Top Cap & Bolt. See Figure W.

Rotate the #13 Right Handlebar Assembly to the desired fit position then carefully retighten the #12 Headset Top Cap and Bolt only until play is removed from headset bearing assembly and the #3 Right Front Wheel Assembly still turns smoothly. Do not over tighten bearing assembly.

Tighten clamp bolts on #13 Right Handlebar Assembly until secure.

Repeat adjustments for #14 Left Handlebar Assembly.

Recheck handlebar and headset adjustments after a short test ride.

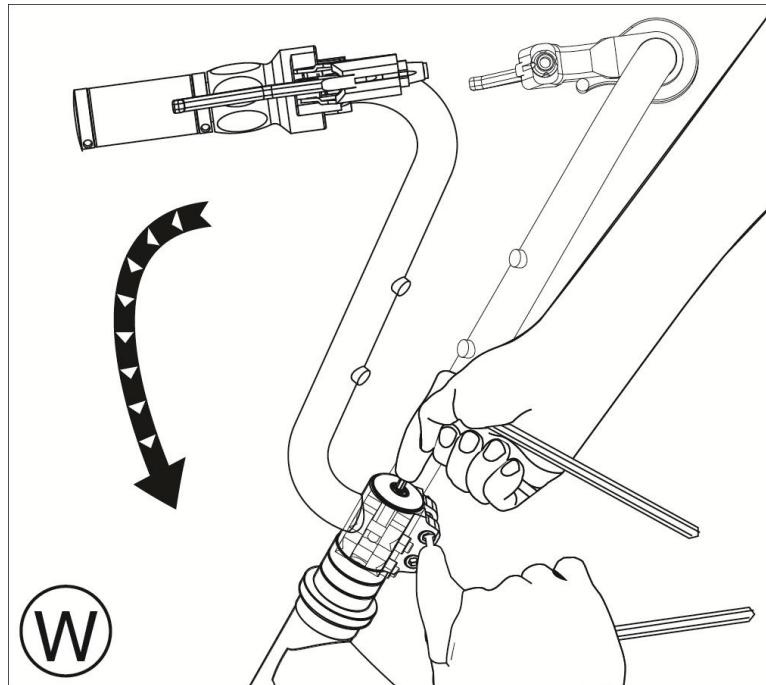

⚠ WARNING: Make sure that once you have made all your handlebar adjustments, you have sufficient clearance from your hands to your tires or wheels and that control cables are secured away from all moving parts. Failure to do so may result in loss of control resulting in a serious or fatal accident.

Sun Seeker Bicycles
PO Box 161859, Miami, FL 33116-1859
info@sunseeker.bike